



e-mail: serwis@techsterowniki.pl

phone: +48 33 875 93 80

ul. Skotnica 120, 32-652 Bulowice

Service:

ul. Biała Droga 31, 34-122 Wieprz

Central headquarters:

EN

USER'S MANUAL
STZ-180 RS n

TECH
CONTROLLERS

TECH
CONTROLLERS

WARRANTY CARD

TECH company ensures to the Buyer proper operation of the device for the period of 24 months from the date of sale. The Guarantor undertakes to repair the device free of charge if the defects occurred through the manufacturer's fault. The device should be delivered to its manufacturer. Principles of conduct in the case of a complaint are determined by the Act on specific terms and conditions of consumer sale and amendments of the Civil Code (Journal of Laws of 5 September 2002).

CAUTION! THE TEMPERATURE SENSOR CANNOT BE IMMERSED IN ANY LIQUID (OIL ETC). THIS MAY RESULT IN DAMAGING THE CONTROLLER AND LOSS OF WARRANTY! THE ACCEPTABLE RELATIVE HUMIDITY OF THE CONTROLLER'S ENVIRONMENT IS 5÷85% REL.H. WITHOUT THE STEAM CONDENSATION EFFECT. THE DEVICE IS NOT INTENDED TO BE OPERATED BY CHILDREN.

Activities related to setting and regulation of the controller parameters described in the Instruction Manual and parts wearing out during normal operation, such as fuses, are not covered by warranty repairs. The warranty does not cover damages arising as a result of improper operation or through the user's fault, mechanical damage or damage created as a result of fire, flood, atmospheric discharges, overvoltage or short-circuit. The interference of an unauthorized service, willful repairs, modifications and construction changes cause the loss of Warranty. TECH controllers have protective seals. Removing a seal results in the loss of Warranty.

The costs of unjustifiable service call to a defect will be borne exclusively by the buyer. The unjustifiable service call is defined as a call to remove damages not resulting from the Guarantor's fault as well as a call considered unjustifiable by the service after diagnosing the device (e.g. damage of the equipment through the fault of the client or not subject to Warranty), or if the device defect occurred for reasons lying beyond the device.

In order to execute the rights arising from this Warranty, the user is obliged, at his own cost and risk, deliver the device to the Guarantor along with a correctly filled-in warranty card (containing in particular the sale date, the seller's signature and a description of the defect) and sales proof (receipt, VAT invoice, etc.). The Warranty Card is the only basis for repair free of charge. The complaint repair time is 14 days.

When the Warranty Card is lost or damaged, the manufacturer does not issue a duplicate.

.....
seller's stamp

.....
date of sale

Safety

Before using the device for the first time the user should read the following regulations carefully. Not obeying the rules included in this manual may lead to personal injuries or controller damage. The user's manual should be stored in a safe place for further reference. In order to avoid accidents and errors it should be ensured that every person using the device has familiarized themselves with the principle of operation as well as security functions of the controller. If the device is to be sold or put in a different place, make sure that the user's manual is there with the device so that any potential user has access to essential information about the device.

The manufacturer does not accept responsibility for any injuries or damage resulting from negligence; therefore, users are obliged to take the necessary safety measures listed in this manual to protect their lives and property.



WARNING

- Installation should be carried out by a person holding appropriate electrical qualifications.
- The device is not intended for use by children.
- The actuator may not be used contrary to its intended purpose.



We are committed to protecting the environment. Manufacturing electronic devices imposes an obligation of providing for environmentally safe disposal of used electronic components and devices. Hence, we have been entered into a register kept by the Inspection For Environmental Protection. The crossed-out bin symbol on a product means that the product may not be disposed of to household waste containers. Recycling of wastes helps to protect the environment. The user is obliged to transfer their used equipment to a collection point where all electric and electronic components.

EU Declaration of conformity

Hereby, we declare under our sole responsibility that **STZ-180 RS n** manufactured by TECH STEROWNIKI, head-quartered in Wieprz Biała Droga 31, 34-122 Wieprz, is compliant with Directive 2014/35/EU of the European Parliament and of the Council of 26 February 2014 on the harmonisation of the laws of Member States relating to the making available on the market of electrical equipment designed for use within certain voltage limits (EU OJ L 96, of 29.03.2014, p. 357), Directive 2014/30/EU of the European Parliament and of the Council of 26 February 2014 on the harmonisation of the laws of Member States relating to electromagnetic compatibility (EU OJ L 96 of 29.03.2014, p.79), Directive 2009/125/EC establishing a framework for the setting of ecodesign requirements for energy-related products as well as the regulation by the MINISTRY OF ENTREPRENEURSHIP AND TECHNOLOGY of 24 June 2019 amending the regulation concerning the essential requirements as regards the restriction of the use of certain hazardous substances in electrical and electronic equipment, implementing provisions of Directive (EU) 2017/2102 of the European Parliament and of the Council of 15 November 2017 amending Directive 2011/65/EU on the restriction of the use of certain hazardous substances in electrical and electronic equipment (OJ L 305, 21.11.2017, p. 8).

For compliance assessment, harmonized standards were used:

PN-EN IEC 60730-2-9:2019-06,

PN-EN 60730-1:2016-10,

EN IEC 63000:2018 RoHS.

Technical data

Power supply	12V DC
Maximum power consumption	1,5W
Ambient temperature	5°C ÷ 50°C
90° rotation time	180 sec.

Description

The STZ-180 RS n actuator is used to control three-way and four-way mixing valves. It is controlled by a 3-point signal. The actuator has a manual control option accessed with use of a pull-out knob. It is also equipped with a display and a valve temperature sensor. The rotation range of the actuator is 90° and the rotation time is 180s.

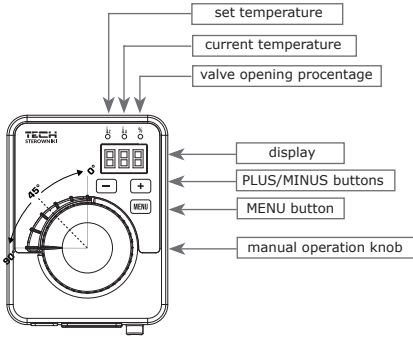

The STZ-180 RS n actuator is supplied with an adapter that allows for its easy installation on the rotary mixing valve.

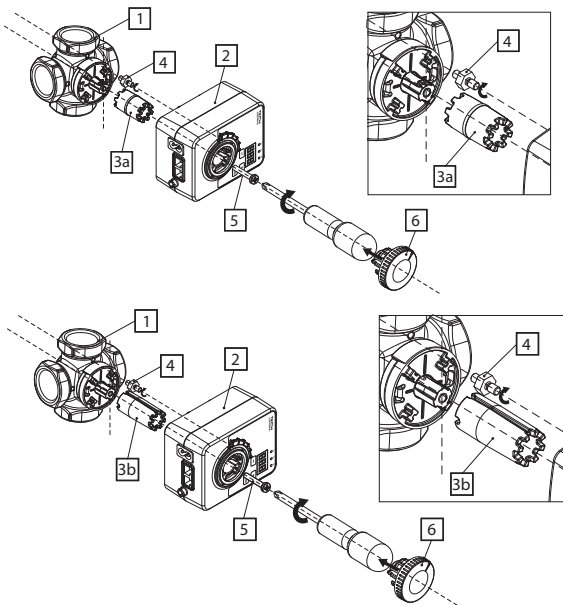
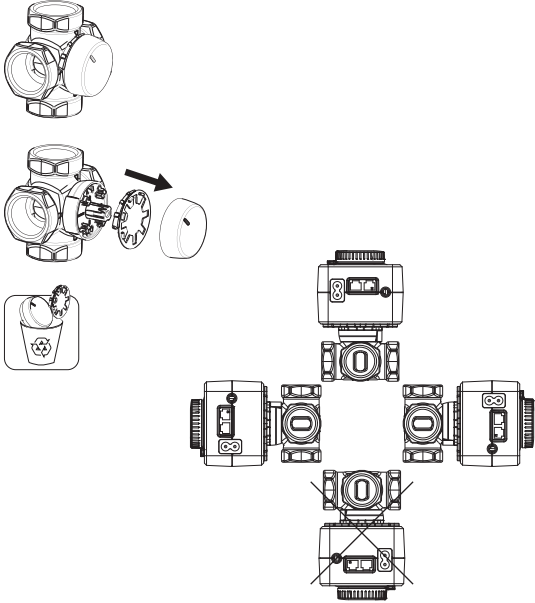

Operating

When the actuator is started, the programme number is displayed for 10 seconds. After this time, the displayed values for the set and current temperature and the percentage of valve opening change every 5 seconds. When calibrating the valve, instead of the percentage value of the valve opening, **CAL** will be displayed.

Use the MENU button to enter the menu function. Switching parameters of the menu functions is done using the PLUS and MINUS buttons. To edit the selected parameter, use the MENU button.

MENU functions:

ON/OFF - current valve status: ON or OFF
t. CH/t. FL - valve type: CH or Floor (FL)
d.L/d.r - change valve opening direction
FAC - restore the factory settings (hold the MENU button for approx. 3 secs.)
Pr - manual operation functions
E--- - exit from the menu

The auxiliary switch (set to any position) is available as pre-installed equipment or as optional equipment. After removing the knob under which the cam is located, adjusting the auxiliary switch is easy and does not require disassembly or the use of any tools.

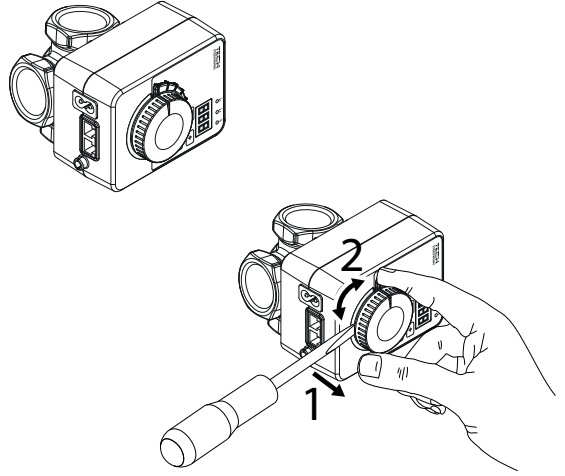

Installation

CAUTION

- Installation should be carried out by a person holding appropriate electrical qualifications!
- Before installing the actuator please familiarize yourself with the following diagrams!

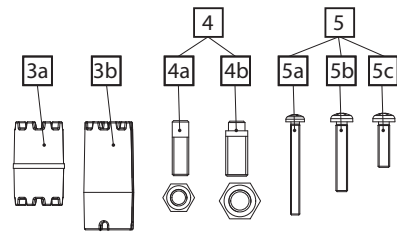
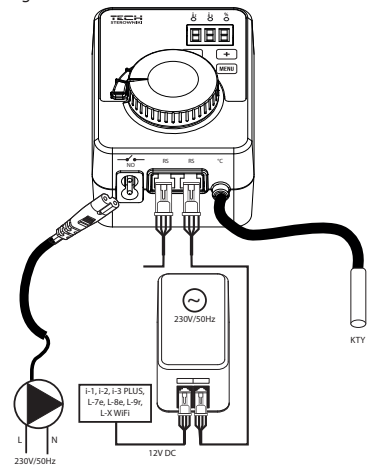

- Valve
- Actuator
- 3a. for numerous valves, including ESBE, Afriso, Herz, Womix, Honeywell
3b. for Wita valves
- depending on the type of thread on the valve
 - 4a. positioning screw and M6 nut
 - 4b. positioning screw and M8 nut
- 5a. for Wita valves
5b/5c. for numerous valves, including ESBE, Afriso, Herz, Womix, Honeywell
- Knob

Use

Thanks to the special clutch between the STZ-180 RS n actuator and the mixing valves, the whole set is characterized by exceptional stability and precision of adjustment.

The STZ-180 RS n actuator operate with the following valves:

ESBE	Herz	Honeywell	Afriso	Womix	Wita
------	------	-----------	--------	-------	------

MANUAL OPERATION functions :

To enter the manual operation function menu, find „Pr“ in the function menu and confirm with the MENU button. Then use the PLUS/MINUS buttons to navigate through the menu of the manual operation function. Changes of individual parameters can be confirmed by pressing the MENU button.

- 0/1 .P** - Valve pump
- 0/1 .O** - Opening
- 0/1 .C** - Closing
- E---** - exit from the menu

The valve setpoint temperature screen alternates between the setpoint and current temperature and the percentage of valve opening. To edit the set temperature, use the PLUS/MINUS buttons until the temperature starts to change.

Registration

The STZ-180 RS n actuator can operate independently or (following the registration process) via the main controller. Depending on the connected controller, its operating functions can be extended.

A detailed description of the registration process is found in the manual of the main controller.